

FULLY DIGITAL GLITCH FREE PLL

KEY FEATURES

- Ideal as a clock generator for digital design
- Excellent frequency jitter performance
- Ultra-low area fully digital PLL design
- Patented glitch free frequency adjustment
- Fine frequency precision with fractional divider
- Low implementation charges due to predictable digital design

DESCRIPTION

A programmable fully digital PLL (FDPLL) designed to lock to an incoming clock source and produce an output clock.

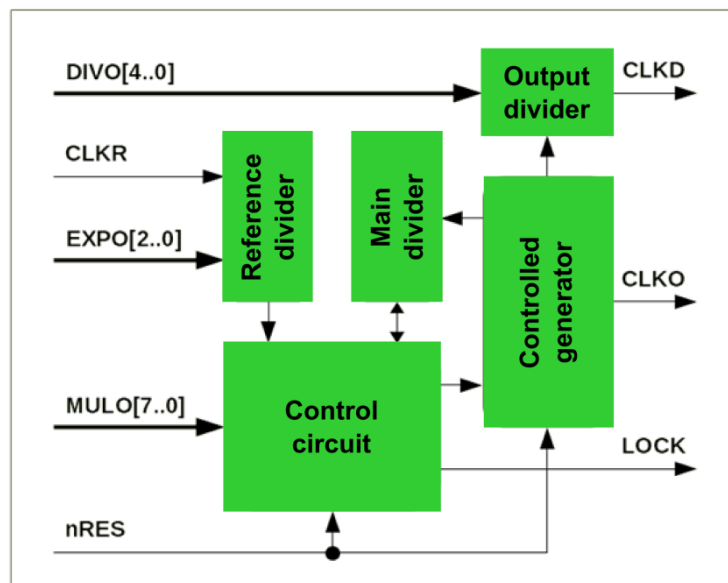

MULO, together with the *EXPO* value, represents a denormalized floating-point number, which is the generation frequency/reference frequency ratio.

The *EXPO* value is equal to the position of the binary point in the binary *MULO* code, counting from its least significant bits.

Moreover, $EXPO = 0$ corresponds to the position of the point to the right of the $MULO$ least significant bit, and $EXPO = 7$ corresponds to the position of the point to the right of the $MULO$ most significant bit, respectively.

$$F(CLKO) = K \cdot F(CLKR)$$

Coefficient K is associated with $MULO$ and $EXPO$ as follows:

$$K = \frac{MULO}{2^{EXPO}}$$

where the value $MULO = 0$ is forbidden

Based on this, the multiplier K in the formula can be in the range of values from 0.0078125 to 255 , setting both the frequency multiplication and division modes. You can use any of 2040 values of K .

PLL CHARACTERISTICS

Parameter	Unit	Min	Typ	Max	Comment
CLKR reference frequency	MHz	0.8		1000	
CLKO output frequency range	MHz	200		2000	
CLKD output frequency	MHz	3.125		1000	
CLKO jitter	%		1		CLKO=600 MHz
				2	CLKO=1000 MHz
CLKO output duty cycle	%	45	50	55	
Power consumption	mW		5		CLKO=1000 MHz
Operational voltage	V	0.8	0.9	1.0	Digital only
Total area	mm ²		0.012		
Operational temperature	°C	0	70	85	

PIN LIST

Signal	Direction	Comment
nRES	input	Asynchronous reset input (Active Low)
CLKR	input	Reference frequency input
MULO[7..0]	input	Multiplication factor mantissa input
EXPO[2..0]	input	Multiplication factor exponent input
DIVO[4..0]	input	Post-divider factor input
CLKO	output	Basic frequency output
CLKD	output	Post-divider output
LOCK	output	Capture indication output

COEFFICIENT K POSSIBLE VALUES

MULO	EXPO							
	EXPO=0	EXPO=1	EXPO=2	EXPO=3	EXPO=4	EXPO=5	EXPO=6	EXPO=7
1	1	0,5	0,25	0,125	0,0625	0,03125	0,015625	0,0078125
2	2	1	0,5	0,25	0,125	0,0625	0,03125	0,015625
3	3	1,5	0,75	0,375	0,1875	0,09375	0,046875	0,0234375
4	4	2	1	0,5	0,25	0,125	0,0625	0,03125
5	5	2,5	1,25	0,625	0,3125	0,15625	0,078125	0,0390625
6	6	3	1,5	0,75	0,375	0,1875	0,09375	0,046875
7	7	3,5	1,75	0,875	0,4375	0,21875	0,109375	0,0546875
8	8	4	2	1	0,5	0,25	0,125	0,0625
9	9	4,5	2,25	1,125	0,5625	0,28125	0,140625	0,0703125
10	10	5	2,5	1,25	0,625	0,3125	0,15625	0,078125
11	11	5,5	2,75	1,375	0,6875	0,34375	0,171875	0,0859375
12	12	6	3	1,5	0,75	0,375	0,1875	0,09375
13	13	6,5	3,25	1,625	0,8125	0,40625	0,203125	0,1015625
14	14	7	3,5	1,75	0,875	0,4375	0,21875	0,109375
15	15	7,5	3,75	1,875	0,9375	0,46875	0,234375	0,1171875
16	16	8	4	2	1	0,5	0,25	0,125
17	17	8,5	4,25	2,125	1,0625	0,53125	0,265625	0,1328125
18	18	9	4,5	2,25	1,125	0,5625	0,28125	0,140625
19	19	9,5	4,75	2,375	1,1875	0,59375	0,296875	0,1484375
20	20	10	5	2,5	1,25	0,625	0,3125	0,15625
21	21	10,5	5,25	2,625	1,3125	0,65625	0,328125	0,1640625
22	22	11	5,5	2,75	1,375	0,6875	0,34375	0,171875
23	23	11,5	5,75	2,875	1,4375	0,71875	0,359375	0,1796875
24	24	12	6	3	1,5	0,75	0,375	0,1875
25	25	12,5	6,25	3,125	1,5625	0,78125	0,390625	0,1953125
26	26	13	6,5	3,25	1,625	0,8125	0,40625	0,203125
27	27	13,5	6,75	3,375	1,6875	0,84375	0,421875	0,2109375
28	28	14	7	3,5	1,75	0,875	0,4375	0,21875
29	29	14,5	7,25	3,625	1,8125	0,90625	0,453125	0,2265625
30	30	15	7,5	3,75	1,875	0,9375	0,46875	0,234375
31	31	15,5	7,75	3,875	1,9375	0,96875	0,484375	0,2421875
32	32	16	8	4	2	1	0,5	0,25
33	33	16,5	8,25	4,125	2,0625	1,03125	0,515625	0,2578125
34	34	17	8,5	4,25	2,125	1,0625	0,53125	0,265625
35	35	17,5	8,75	4,375	2,1875	1,09375	0,546875	0,2734375
36	36	18	9	4,5	2,25	1,125	0,5625	0,28125
37	37	18,5	9,25	4,625	2,3125	1,15625	0,578125	0,2890625
38	38	19	9,5	4,75	2,375	1,1875	0,59375	0,296875
39	39	19,5	9,75	4,875	2,4375	1,21875	0,609375	0,3046875
40	40	20	10	5	2,5	1,25	0,625	0,3125
41	41	20,5	10,25	5,125	2,5625	1,28125	0,640625	0,3203125
42	42	21	10,5	5,25	2,625	1,3125	0,65625	0,328125
43	43	21,5	10,75	5,375	2,6875	1,34375	0,671875	0,3359375
44	44	22	11	5,5	2,75	1,375	0,6875	0,34375
45	45	22,5	11,25	5,625	2,8125	1,40625	0,703125	0,3515625
46	46	23	11,5	5,75	2,875	1,4375	0,71875	0,359375
47	47	23,5	11,75	5,875	2,9375	1,46875	0,734375	0,3671875
48	48	24	12	6	3	1,5	0,75	0,375
49	49	24,5	12,25	6,125	3,0625	1,53125	0,765625	0,3828125
50	50	25	12,5	6,25	3,125	1,5625	0,78125	0,390625
51	51	25,5	12,75	6,375	3,1875	1,59375	0,796875	0,3984375
53	53	26,5	13,25	6,625	3,3125	1,65625	0,828125	0,4140625
54	54	27	13,5	6,75	3,375	1,6875	0,84375	0,421875
55	55	27,5	13,75	6,875	3,4375	1,71875	0,859375	0,4296875

MULO	EXPO							
	EXPO=0	EXPO=1	EXPO=2	EXPO=3	EXPO=4	EXPO=5	EXPO=6	EXPO=7
56	56	28	14	7	3,5	1,75	0,875	0,4375
57	57	28,5	14,25	7,125	3,5625	1,78125	0,890625	0,4453125
58	58	29	14,5	7,25	3,625	1,8125	0,90625	0,453125
59	59	29,5	14,75	7,375	3,6875	1,84375	0,921875	0,4609375
60	60	30	15	7,5	3,75	1,875	0,9375	0,46875
61	61	30,5	15,25	7,625	3,8125	1,90625	0,953125	0,4765625
62	62	31	15,5	7,75	3,875	1,9375	0,96875	0,484375
63	63	31,5	15,75	7,875	3,9375	1,96875	0,984375	0,4921875
64	64	32	16	8	4	2	1	0,5
65	65	32,5	16,25	8,125	4,0625	2,03125	1,015625	0,5078125
66	66	33	16,5	8,25	4,125	2,0625	1,03125	0,515625
67	67	33,5	16,75	8,375	4,1875	2,09375	1,046875	0,5234375
68	68	34	17	8,5	4,25	2,125	1,0625	0,53125
69	69	34,5	17,25	8,625	4,3125	2,15625	1,078125	0,5390625
70	70	35	17,5	8,75	4,375	2,1875	1,09375	0,546875
71	71	35,5	17,75	8,875	4,4375	2,21875	1,109375	0,5546875
72	72	36	18	9	4,5	2,25	1,125	0,5625
73	73	36,5	18,25	9,125	4,5625	2,28125	1,140625	0,5703125
74	74	37	18,5	9,25	4,625	2,3125	1,15625	0,578125
75	75	37,5	18,75	9,375	4,6875	2,34375	1,171875	0,5859375
76	76	38	19	9,5	4,75	2,375	1,1875	0,59375
77	77	38,5	19,25	9,625	4,8125	2,40625	1,203125	0,6015625
78	78	39	19,5	9,75	4,875	2,4375	1,21875	0,609375
79	79	39,5	19,75	9,875	4,9375	2,46875	1,234375	0,6171875
80	80	40	20	10	5	2,5	1,25	0,625
81	81	40,5	20,25	10,125	5,0625	2,53125	1,265625	0,6328125
82	82	41	20,5	10,25	5,125	2,5625	1,28125	0,640625
83	83	41,5	20,75	10,375	5,1875	2,59375	1,296875	0,6484375
84	84	42	21	10,5	5,25	2,625	1,3125	0,65625
85	85	42,5	21,25	10,625	5,3125	2,65625	1,328125	0,6640625
86	86	43	21,5	10,75	5,375	2,6875	1,34375	0,671875
87	87	43,5	21,75	10,875	5,4375	2,71875	1,359375	0,6796875
88	88	44	22	11	5,5	2,75	1,375	0,6875
89	89	44,5	22,25	11,125	5,5625	2,78125	1,390625	0,6953125
90	90	45	22,5	11,25	5,625	2,8125	1,40625	0,703125
91	91	45,5	22,75	11,375	5,6875	2,84375	1,421875	0,7109375
92	92	46	23	11,5	5,75	2,875	1,4375	0,71875
93	93	46,5	23,25	11,625	5,8125	2,90625	1,453125	0,7265625
94	94	47	23,5	11,75	5,875	2,9375	1,46875	0,734375
95	95	47,5	23,75	11,875	5,9375	2,96875	1,484375	0,7421875
96	96	48	24	12	6	3	1,5	0,75
97	97	48,5	24,25	12,125	6,0625	3,03125	1,515625	0,7578125
98	98	49	24,5	12,25	6,125	3,0625	1,53125	0,765625
99	99	49,5	24,75	12,375	6,1875	3,09375	1,546875	0,7734375
100	100	50	25	12,5	6,25	3,125	1,5625	0,78125
101	101	50,5	25,25	12,625	6,3125	3,15625	1,578125	0,7890625
103	103	51,5	25,75	12,875	6,4375	3,21875	1,609375	0,8046875
104	104	52	26	13	6,5	3,25	1,625	0,8125
105	105	52,5	26,25	13,125	6,5625	3,28125	1,640625	0,8203125
106	106	53	26,5	13,25	6,625	3,3125	1,65625	0,828125
107	107	53,5	26,75	13,375	6,6875	3,34375	1,671875	0,8359375
108	108	54	27	13,5	6,75	3,375	1,6875	0,84375
109	109	54,5	27,25	13,625	6,8125	3,40625	1,703125	0,8515625
110	110	55	27,5	13,75	6,875	3,4375	1,71875	0,859375
111	111	55,5	27,75	13,875	6,9375	3,46875	1,734375	0,8671875
112	112	56	28	14	7	3,5	1,75	0,875

MULO	EXPO							
	EXPO=0	EXPO=1	EXPO=2	EXPO=3	EXPO=4	EXPO=5	EXPO=6	EXPO=7
113	113	56,5	28,25	14,125	7,0625	3,53125	1,765625	0,8828125
114	114	57	28,5	14,25	7,125	3,5625	1,78125	0,890625
115	115	57,5	28,75	14,375	7,1875	3,59375	1,796875	0,8984375
116	116	58	29	14,5	7,25	3,625	1,8125	0,90625
117	117	58,5	29,25	14,625	7,3125	3,65625	1,828125	0,9140625
118	118	59	29,5	14,75	7,375	3,6875	1,84375	0,921875
119	119	59,5	29,75	14,875	7,4375	3,71875	1,859375	0,9296875
120	120	60	30	15	7,5	3,75	1,875	0,9375
121	121	60,5	30,25	15,125	7,5625	3,78125	1,890625	0,9453125
122	122	61	30,5	15,25	7,625	3,8125	1,90625	0,953125
123	123	61,5	30,75	15,375	7,6875	3,84375	1,921875	0,9609375
124	124	62	31	15,5	7,75	3,875	1,9375	0,96875
125	125	62,5	31,25	15,625	7,8125	3,90625	1,953125	0,9765625
126	126	63	31,5	15,75	7,875	3,9375	1,96875	0,984375
127	127	63,5	31,75	15,875	7,9375	3,96875	1,984375	0,9921875
128	128	64	32	16	8	4	2	1
129	129	64,5	32,25	16,125	8,0625	4,03125	2,015625	1,0078125
130	130	65	32,5	16,25	8,125	4,0625	2,03125	1,015625
131	131	65,5	32,75	16,375	8,1875	4,09375	2,046875	1,0234375
132	132	66	33	16,5	8,25	4,125	2,0625	1,03125
133	133	66,5	33,25	16,625	8,3125	4,15625	2,078125	1,0390625
134	134	67	33,5	16,75	8,375	4,1875	2,09375	1,046875
135	135	67,5	33,75	16,875	8,4375	4,21875	2,109375	1,0546875
136	136	68	34	17	8,5	4,25	2,125	1,0625
137	137	68,5	34,25	17,125	8,5625	4,28125	2,140625	1,0703125
138	138	69	34,5	17,25	8,625	4,3125	2,15625	1,078125
139	139	69,5	34,75	17,375	8,6875	4,34375	2,171875	1,0859375
140	140	70	35	17,5	8,75	4,375	2,1875	1,09375
141	141	70,5	35,25	17,625	8,8125	4,40625	2,203125	1,1015625
142	142	71	35,5	17,75	8,875	4,4375	2,21875	1,109375
143	143	71,5	35,75	17,875	8,9375	4,46875	2,234375	1,1171875
144	144	72	36	18	9	4,5	2,25	1,125
145	145	72,5	36,25	18,125	9,0625	4,53125	2,265625	1,1328125
146	146	73	36,5	18,25	9,125	4,5625	2,28125	1,140625
147	147	73,5	36,75	18,375	9,1875	4,59375	2,296875	1,1484375
148	148	74	37	18,5	9,25	4,625	2,3125	1,15625
149	149	74,5	37,25	18,625	9,3125	4,65625	2,328125	1,1640625
150	150	75	37,5	18,75	9,375	4,6875	2,34375	1,171875
151	151	75,5	37,75	18,875	9,4375	4,71875	2,359375	1,1796875
153	153	76,5	38,25	19,125	9,5625	4,78125	2,390625	1,1953125
154	154	77	38,5	19,25	9,625	4,8125	2,40625	1,203125
155	155	77,5	38,75	19,375	9,6875	4,84375	2,421875	1,2109375
156	156	78	39	19,5	9,75	4,875	2,4375	1,21875
157	157	78,5	39,25	19,625	9,8125	4,90625	2,453125	1,2265625
158	158	79	39,5	19,75	9,875	4,9375	2,46875	1,234375
159	159	79,5	39,75	19,875	9,9375	4,96875	2,484375	1,2421875
160	160	80	40	20	10	5	2,5	1,25
161	161	80,5	40,25	20,125	10,0625	5,03125	2,515625	1,2578125
162	162	81	40,5	20,25	10,125	5,0625	2,53125	1,265625
163	163	81,5	40,75	20,375	10,1875	5,09375	2,546875	1,2734375
164	164	82	41	20,5	10,25	5,125	2,5625	1,28125
165	165	82,5	41,25	20,625	10,3125	5,15625	2,578125	1,2890625
166	166	83	41,5	20,75	10,375	5,1875	2,59375	1,296875
167	167	83,5	41,75	20,875	10,4375	5,21875	2,609375	1,3046875
168	168	84	42	21	10,5	5,25	2,625	1,3125
169	169	84,5	42,25	21,125	10,5625	5,28125	2,640625	1,3203125

MULO	EXPO							
	EXPO=0	EXPO=1	EXPO=2	EXPO=3	EXPO=4	EXPO=5	EXPO=6	EXPO=7
170	170	85	42,5	21,25	10,625	5,3125	2,65625	1,328125
171	171	85,5	42,75	21,375	10,6875	5,34375	2,671875	1,3359375
172	172	86	43	21,5	10,75	5,375	2,6875	1,34375
173	173	86,5	43,25	21,625	10,8125	5,40625	2,703125	1,3515625
174	174	87	43,5	21,75	10,875	5,4375	2,71875	1,359375
175	175	87,5	43,75	21,875	10,9375	5,46875	2,734375	1,3671875
176	176	88	44	22	11	5,5	2,75	1,375
177	177	88,5	44,25	22,125	11,0625	5,53125	2,765625	1,3828125
178	178	89	44,5	22,25	11,125	5,5625	2,78125	1,390625
179	179	89,5	44,75	22,375	11,1875	5,59375	2,796875	1,3984375
180	180	90	45	22,5	11,25	5,625	2,8125	1,40625
181	181	90,5	45,25	22,625	11,3125	5,65625	2,828125	1,4140625
182	182	91	45,5	22,75	11,375	5,6875	2,84375	1,421875
183	183	91,5	45,75	22,875	11,4375	5,71875	2,859375	1,4296875
184	184	92	46	23	11,5	5,75	2,875	1,4375
185	185	92,5	46,25	23,125	11,5625	5,78125	2,890625	1,4453125
186	186	93	46,5	23,25	11,625	5,8125	2,90625	1,453125
187	187	93,5	46,75	23,375	11,6875	5,84375	2,921875	1,4609375
188	188	94	47	23,5	11,75	5,875	2,9375	1,46875
189	189	94,5	47,25	23,625	11,8125	5,90625	2,953125	1,4765625
190	190	95	47,5	23,75	11,875	5,9375	2,96875	1,484375
191	191	95,5	47,75	23,875	11,9375	5,96875	2,984375	1,4921875
192	192	96	48	24	12	6	3	1,5
193	193	96,5	48,25	24,125	12,0625	6,03125	3,015625	1,5078125
194	194	97	48,5	24,25	12,125	6,0625	3,03125	1,515625
195	195	97,5	48,75	24,375	12,1875	6,09375	3,046875	1,5234375
196	196	98	49	24,5	12,25	6,125	3,0625	1,53125
197	197	98,5	49,25	24,625	12,3125	6,15625	3,078125	1,5390625
198	198	99	49,5	24,75	12,375	6,1875	3,09375	1,546875
199	199	99,5	49,75	24,875	12,4375	6,21875	3,109375	1,5546875
200	200	100	50	25	12,5	6,25	3,125	1,5625
201	201	100,5	50,25	25,125	12,5625	6,28125	3,140625	1,5703125
202	202	101	50,5	25,25	12,625	6,3125	3,15625	1,578125
203	203	101,5	50,75	25,375	12,6875	6,34375	3,171875	1,5859375
205	205	102,5	51,25	25,625	12,8125	6,40625	3,203125	1,6015625
206	206	103	51,5	25,75	12,875	6,4375	3,21875	1,609375
207	207	103,5	51,75	25,875	12,9375	6,46875	3,234375	1,6171875
208	208	104	52	26	13	6,5	3,25	1,625
209	209	104,5	52,25	26,125	13,0625	6,53125	3,265625	1,6328125
210	210	105	52,5	26,25	13,125	6,5625	3,28125	1,640625
211	211	105,5	52,75	26,375	13,1875	6,59375	3,296875	1,6484375
212	212	106	53	26,5	13,25	6,625	3,3125	1,65625
213	213	106,5	53,25	26,625	13,3125	6,65625	3,328125	1,6640625
214	214	107	53,5	26,75	13,375	6,6875	3,34375	1,671875
215	215	107,5	53,75	26,875	13,4375	6,71875	3,359375	1,6796875
216	216	108	54	27	13,5	6,75	3,375	1,6875
217	217	108,5	54,25	27,125	13,5625	6,78125	3,390625	1,6953125
218	218	109	54,5	27,25	13,625	6,8125	3,40625	1,703125
219	219	109,5	54,75	27,375	13,6875	6,84375	3,421875	1,7109375
220	220	110	55	27,5	13,75	6,875	3,4375	1,71875
221	221	110,5	55,25	27,625	13,8125	6,90625	3,453125	1,7265625
222	222	111	55,5	27,75	13,875	6,9375	3,46875	1,734375
223	223	111,5	55,75	27,875	13,9375	6,96875	3,484375	1,7421875
224	224	112	56	28	14	7	3,5	1,75
225	225	112,5	56,25	28,125	14,0625	7,03125	3,515625	1,7578125
226	226	113	56,5	28,25	14,125	7,0625	3,53125	1,765625

MULO	EXPO							
	EXPO=0	EXPO=1	EXPO=2	EXPO=3	EXPO=4	EXPO=5	EXPO=6	EXPO=7
227	227	113,5	56,75	28,375	14,1875	7,09375	3,546875	1,7734375
228	228	114	57	28,5	14,25	7,125	3,5625	1,78125
229	229	114,5	57,25	28,625	14,3125	7,15625	3,578125	1,7890625
230	230	115	57,5	28,75	14,375	7,1875	3,59375	1,796875
231	231	115,5	57,75	28,875	14,4375	7,21875	3,609375	1,8046875
232	232	116	58	29	14,5	7,25	3,625	1,8125
233	233	116,5	58,25	29,125	14,5625	7,28125	3,640625	1,8203125
234	234	117	58,5	29,25	14,625	7,3125	3,65625	1,828125
235	235	117,5	58,75	29,375	14,6875	7,34375	3,671875	1,8359375
236	236	118	59	29,5	14,75	7,375	3,6875	1,84375
237	237	118,5	59,25	29,625	14,8125	7,40625	3,703125	1,8515625
238	238	119	59,5	29,75	14,875	7,4375	3,71875	1,859375
239	239	119,5	59,75	29,875	14,9375	7,46875	3,734375	1,8671875
240	240	120	60	30	15	7,5	3,75	1,875
241	241	120,5	60,25	30,125	15,0625	7,53125	3,765625	1,8828125
242	242	121	60,5	30,25	15,125	7,5625	3,78125	1,890625
243	243	121,5	60,75	30,375	15,1875	7,59375	3,796875	1,8984375
244	244	122	61	30,5	15,25	7,625	3,8125	1,90625
245	245	122,5	61,25	30,625	15,3125	7,65625	3,828125	1,9140625
246	246	123	61,5	30,75	15,375	7,6875	3,84375	1,921875
247	247	123,5	61,75	30,875	15,4375	7,71875	3,859375	1,9296875
248	248	124	62	31	15,5	7,75	3,875	1,9375
249	249	124,5	62,25	31,125	15,5625	7,78125	3,890625	1,9453125
250	250	125	62,5	31,25	15,625	7,8125	3,90625	1,953125
251	251	125,5	62,75	31,375	15,6875	7,84375	3,921875	1,9609375
252	252	126	63	31,5	15,75	7,875	3,9375	1,96875
253	253	126,5	63,25	31,625	15,8125	7,90625	3,953125	1,9765625
254	254	127	63,5	31,75	15,875	7,9375	3,96875	1,984375
255	255	127,5	63,75	31,875	15,9375	7,96875	3,984375	1,9921875

info@maltsystem.com